



From waste to electricity

with the Againty ORC System



**We convert your waste
into electric power**

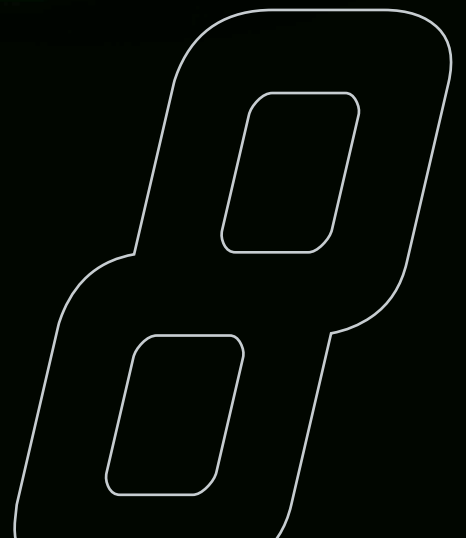

Converting waste into electric power

Againity tackles one of the major problems with solid municipal waste today. Namely that most of it is still dumped at an ever-growing waste disposal site. Both the local and global environment is thereby negatively affected, while energy and materials in the waste is unused.

The Againity waste-to-energy plant is a modern and environmentally sustainable solution that converts waste into hot water and electricity. The technology is based on the latest developments in industrial standards. The waste is incinerated in a boiler that

generates hot water. The hot water is connected to a so called ORC system which produces electricity. State of the art emission control meet the regulations and requirements set by the European Union. The system is built to handle a wide range of sorted industrial, municipal and general waste. Your waste disposal site is turned into a profitable business by selling electricity to the main grid and hot water to e.g. nearby industries, houses or hospitals. The hot water can also be used for a fresh water generator producing drinking water from contaminated water, or for an absorption chiller producing cooling for indoor cooling or food storage. Both systems are offered as add-ons to the waste-to-energy plant.

Let us turn your waste into profit!

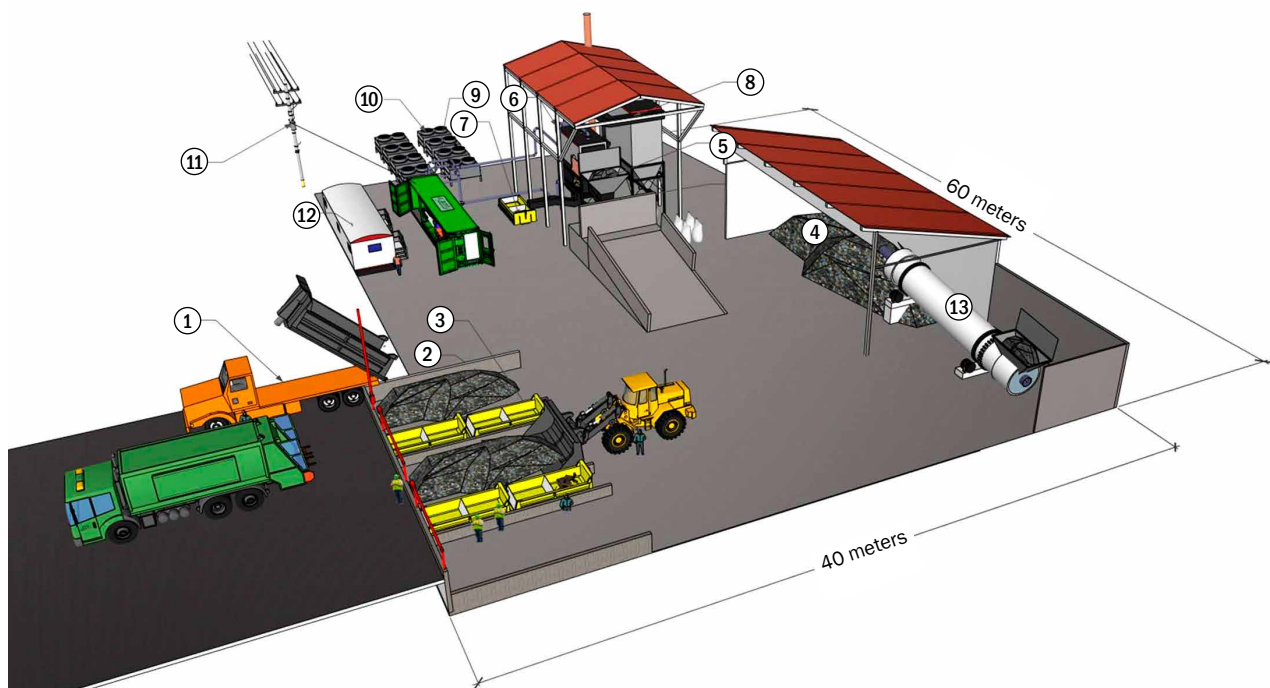

1 The waste disposal truck dumps the waste at the sorting ramp. The ramp manager tells the next truck where to unload and closes the gate when personnel is sorting the waste.

2 The wheel loader flattens the pile for easy access and sorting/recycling of different materials. At least glass, metals, electronics, and batteries should be sorted and thrown into the yellow containers for recycling.

3 The wheel loader moves the waste directly to the boiler or to the intermediate storage area. The volume of the waste is decreased by compressing it against the wall.

4 The intermediate storage area should be sized to handle at least 72 hours of waste under roof for weather protection in order to avoid the wind moving the waste and the rain to increase the moisture of the waste.

5 The automatic inlet feed system compresses the waste to remove liquids and feed the waste to the boiler at a controlled rate.

6 The modern two-zone boiler is constantly controlled by the operator with help of measurement devices and cameras to ensure an optimal efficiency and low emissions.

7 The ash is automatically fed into containers. The ash is normally less than 5% of the waste.

8 The modern electrostatic filter and/or sock filter removes fly ash and small impurities from the exhaust gases.

9 The Againity ORC System is driven by heat from the boiler. Hot water is pumped from the waste boiler to the ORC system that converts heat into electricity which is fed to the grid.

10 If there is no usage for hot water, heat is given off to the atmosphere by fans or to a nearby river or lake.

11 The waste-to-energy plant can be designed for both on-grid and off-grid operation.

12 Office and control room for boiler and ORC.

13 If the moisture content of the waste is too high, a dryer system can be added to the plant.



From heat to electricity – the ORC technology

Againity's ORC system is based on the long-known ORC technology (Organic Rankine Cycle), which is illustrated in the image below. The technology includes a small steam turbine set in motion by the pressure from hot steam. The rotating turbine then drives a generator that produces electricity. In good conditions the electrical efficiency is 20%.

Quality first

Thanks to the unique design of our patent pending turbine and the low number of moving parts in the ORC system, a high-quality product can be offered. This minimizes the need for maintenance and significantly shortens the payback time.

The excess heat from the ORC system can be utilized as hot water for any of the applications described on the bottom of the page.

Flow chart of the Againity ORC System

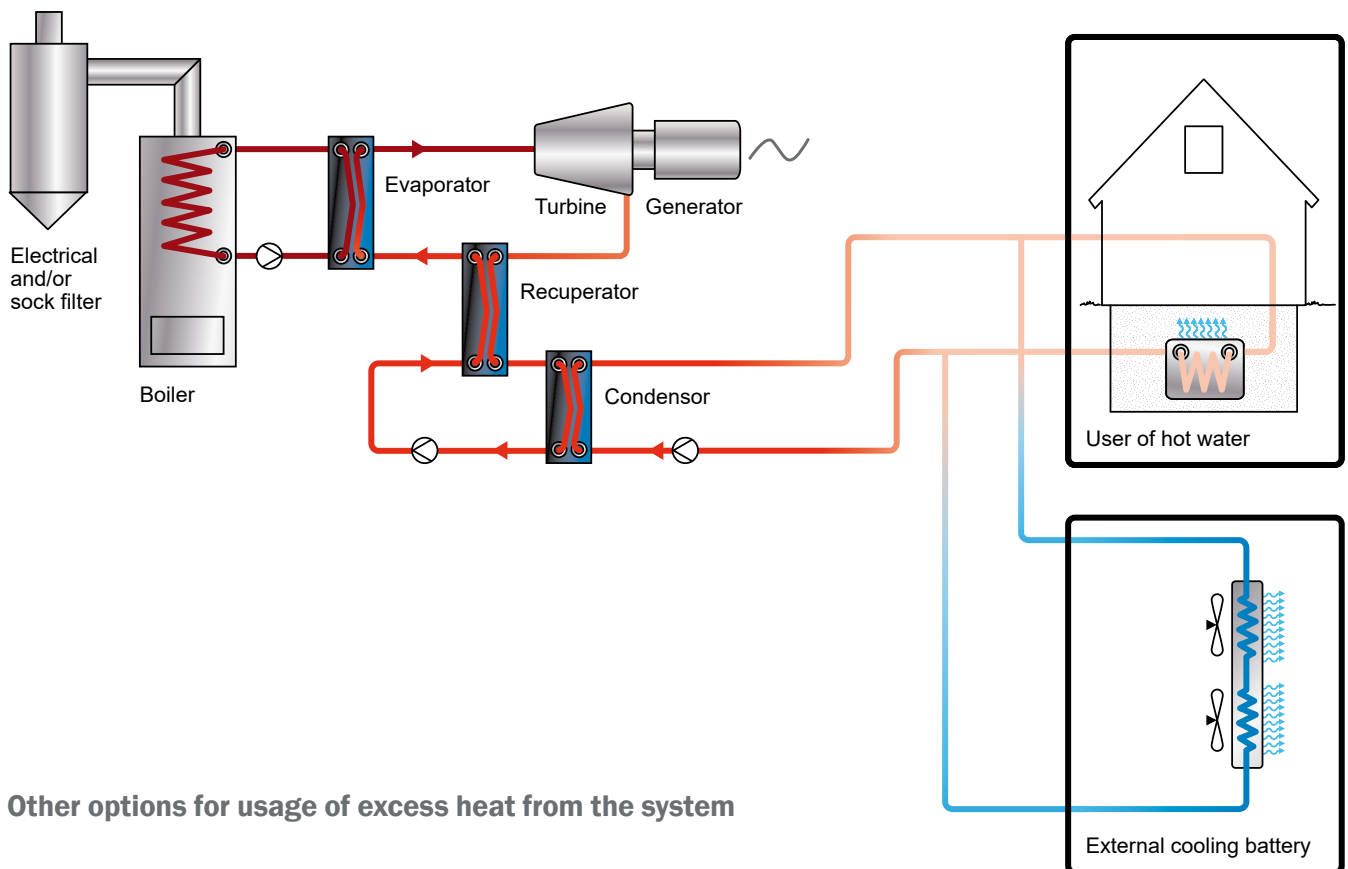

Other options for usage of excess heat from the system

Delivery of cooling

(indoor/fridge)
An absorption chiller produces cooling for e.g. indoor cooling or food storage.

Delivery of freshwater

A freshwater generator turns contaminated water into drinking water with a vacuum distillation process.

River/ocean cooling

The excess heat from the ORC system is cooled by a nearby river or sea.

From waste to electricity with the Againity ORC System

Againity is all about turning waste into value. By utilizing the materials and energy in waste we save money as well as the environment.



The integrated waste management system comes in three different sizes as standard

The heat and electricity production of the plant varies with the content of the incoming waste. With a heating value of the waste of 2.2 MWh/ton the plant will have the following capacity.

Capacity	1.2 ton per hour	2.4 tons per hour	4.8 tons per hour
Electricity production from ORC	240 kW	470 kW	950 kW
Hot water production from ORC	2000 kW	4000 kW	8000 kW
Voltage	380-415 V	380-415 V	380-3000 V
Frequency	50-60 Hz	50-60 Hz	50-60 Hz

Copyright © Againity

Againity AB

Visit and post address: Laxholmstorget 3 (3rd fl), SE-602 21 Norrköping, Sweden

Phone: +46 (0)70 529 32 23, e-mail: info@againity.com

www.againity.com

